

NELSON™ HEAT TRACING SYSTEMS

ALT-BY TEE SPLICE CONNECTION KIT

INSTALLATION INSTRUCTIONS

DESCRIPTION

The ALT-BY Tee Splice Connection Kit is constructed of cast aluminum for use with all versions of Nelson Heat Tracing Systems' LT, CLT, HLT and NC heater cables. Compatible for use with any vendor's heater cables smaller than 11mm (0.44") diameter.

KIT CONTENTS

- | | |
|----------------------|----------------------|
| 1 Junction Box | 3 Power Terminations |
| 1 Terminal Block | 2 Washers |
| 1 Conduit Plug | 1 Ground Screw |
| 2 Sealing Grommets | 2 End Seals |
| 1 Stand-off | 1 Tube of Silicone |
| 1 Flex Tubing | 2 Pipe Clamps |
| 1 Connection Fitting | |

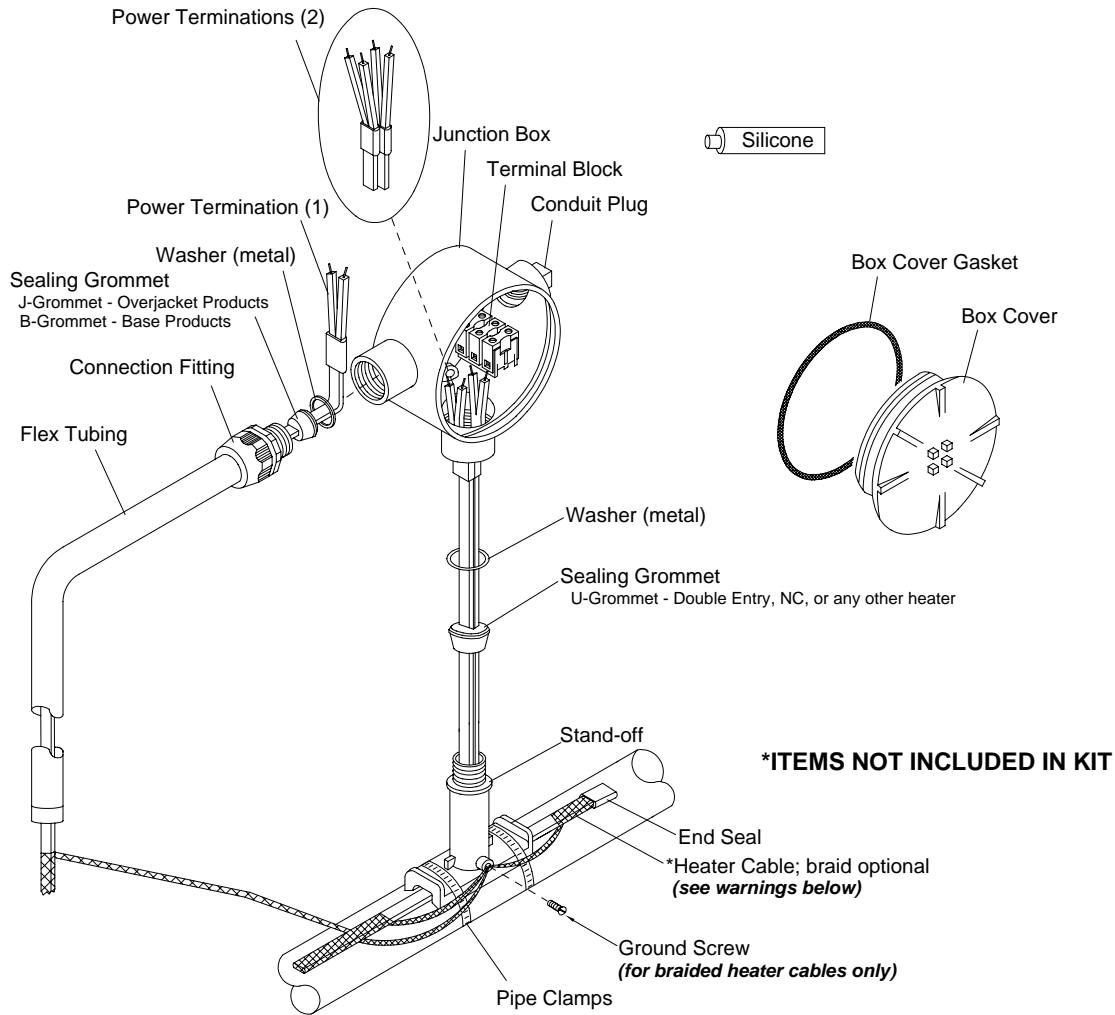

Note: This detail shows external grounding of braid. For internal ground of braid (*overjacket products*), see sheet 8.

⚠ WARNINGS:

- Canadian Div. 2 Hazardous installations must use internal ground connection of braid. See sheet 8.
- Article 427 of the National Electric Code requires that all heaters shall have metal coverings and be provided with branch circuit ground-fault protection.
- If nuisance tripping of ground fault breakers occurs due to condensation in connection box, electrical connection should be moisture proofed by use of a coating or sealant.

NELSON™ HEAT TRACING SYSTEMS

ALT-BY TEE SPLICE CONNECTION KIT

INSTALLATION INSTRUCTIONS

Section View A A

(recommend installing at the
4 or 8 o'clock positions.)

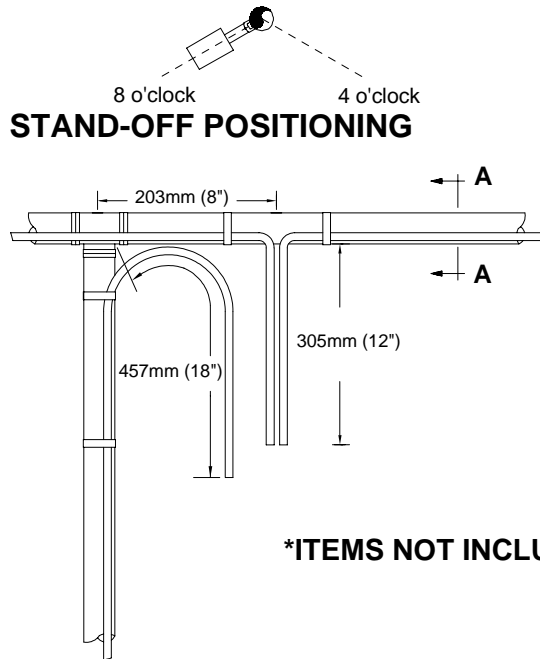

STAND-OFF POSITIONING

***ITEMS NOT INCLUDED IN KIT**

⚠ WARNING:

**Do not place pipe clamps
over the heater cable.**

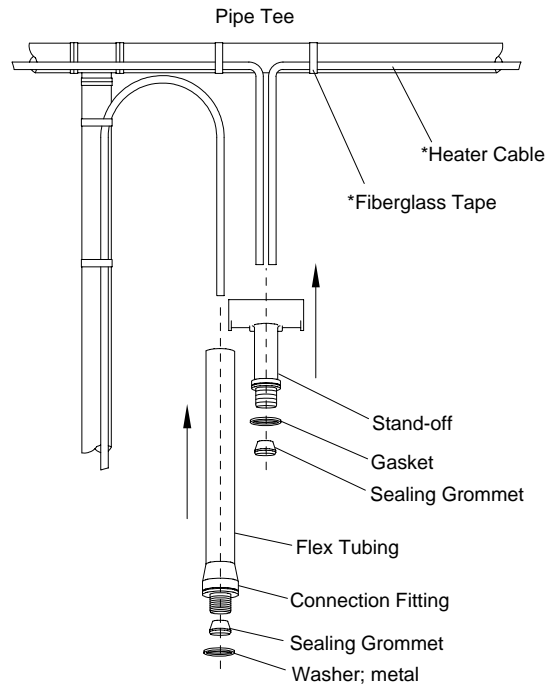

- 1 Cut heater cables to lengths shown.
- 2 **External Braid Connection - CB Products only:**
 - Remove braid from heater cables, back to the point the cables leave the pipe. See Sheet 3.
 - Proceed to step 3 below.
- Internal Braid Connection - CB, J or JT Products:**
Proceed to step 3 below.
- 3 Push the two 305mm (12") heater cables through the bottom opening of stand-off.
- 4 Place stand-off on pipe and fasten with pipe clamps.
- 5 Slide the large opening sealing grommet over the two heater cables and position inside stand-off opening.
- 6 Apply silicone around heater cables on top of the sealing grommet and fill any voids in sealing grommet.
- 7 Install flex tubing assembly over the 457mm (18") heater cable and tape at pipe tee with fiberglass tape (*not included in kit*).
- 8 Slide the gasket and small opening sealing grommet over the single heater cable and position inside connection fitting.
- 9 Apply silicone around heater cable at top of the sealing grommet and fill any voids in sealing grommet.
- 10 Prepare heater cables for power termination: for braided products, see sheet 3. for overjacket products, see sheet 4. for base products, see sheet 5.
- 11 Terminate heater cables, see sheet 7.

BRAIDED PRODUCTS

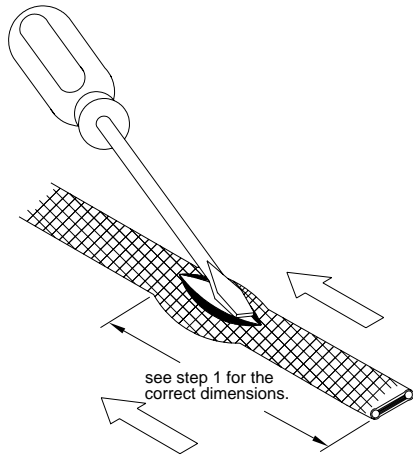

- 1 For External Braid Connection:**
For heater cable going through the flex tubing -
move braid back 457mm (18") to create a bulge.

For heater cables going through the stand-off -
move braid back 305mm (12") to create a bulge.

For Internal Braid Connection:
Move braid back 127mm (5") to create a bulge.

- 2** At the bulge, separate the braid to make an opening.

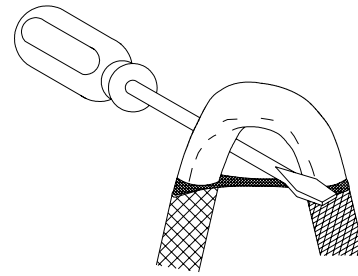

- 3** While bending the heater cable, work it through the braid opening.

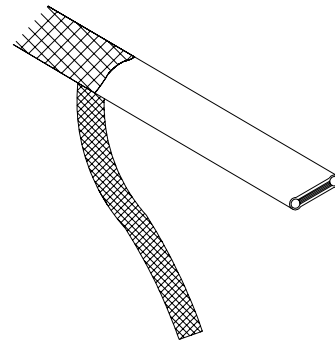

- 4** Pull the braid tight.
5 Proceed to "LT, CLT & HLT Products", sheet 5.

OVERJACKET PRODUCTS

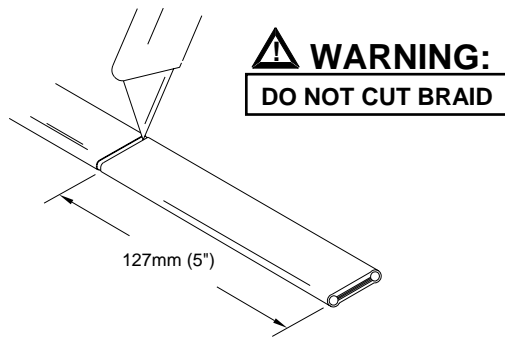

- 1 Lightly cut around heater overjacket 127mm (5") from the end. Bend cable to break overjacket.
- 2 Lightly cut overjacket up the center between first cut mark and the cable end. Bend cable to break overjacket.

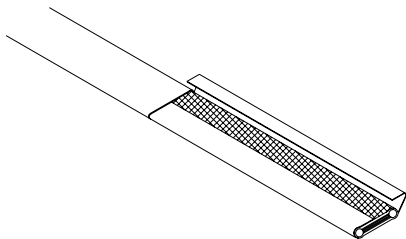

- 3 Remove overjacket from heater cable.

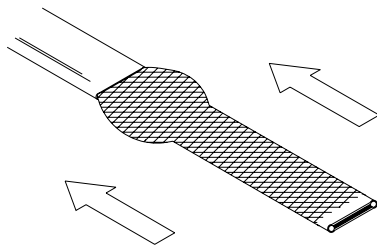

- 4 Move braid back toward the overjacket, creating a bulge.

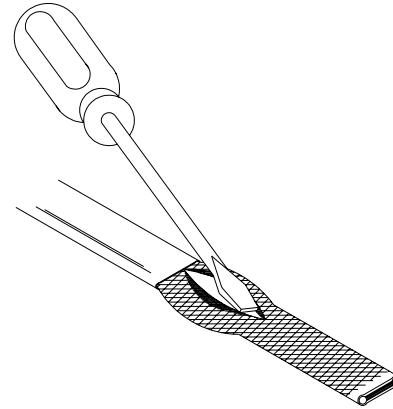

- 5 At the bulge, separate the braid to make an opening.

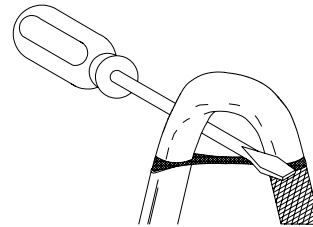

- 6 While bending the heater cable, work it through the braid opening.

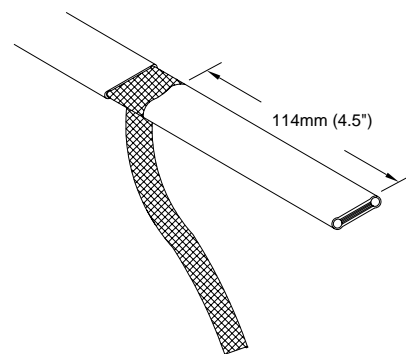

- 7 Pull the braid tight.
- 8 Proceed to "LT, CLT & HLT Products", sheet 5.

NELSON™ HEAT TRACING SYSTEMS

ALT-BY TEE SPLICE CONNECTION KIT

INSTALLATION INSTRUCTIONS

FOR ALL NELSON LT, CLT & HLT PRODUCTS
(See sheet 6 for an alternate method of HLT products.)

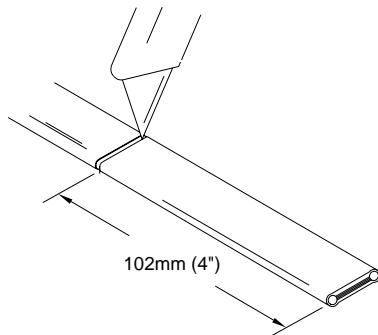

❶ Lightly cut around heater outer jacket 102mm (4") from the end. Bend cable to break outer jacket.

❷ Lightly cut the outer jacket up the center between the first cut mark & the cable end. Bend cable to break outer jacket.

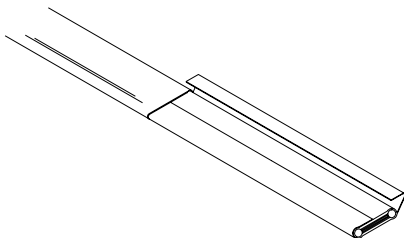

❸ Remove the jacket from the heater cable.

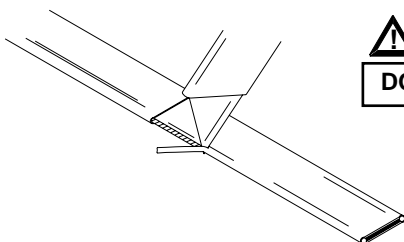

❹ Shave the core material from the outside of each bus wire.

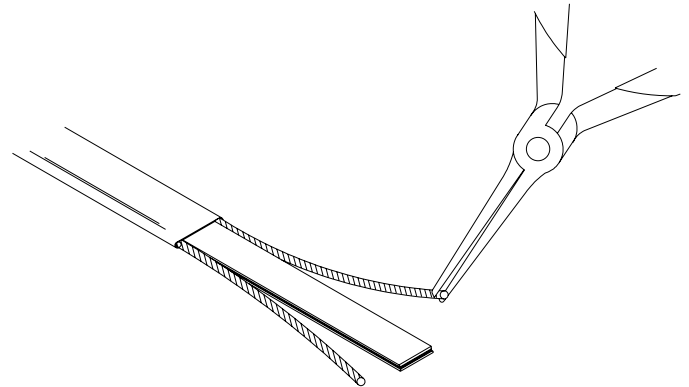

❺ Starting at the end, pull each bus wire away from the core material.

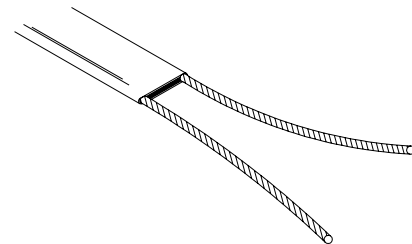

❻ Remove exposed core material.

❼ Cut 6mm (0.25") off the end of each bus wire.

❽ Proceed to "Power Termination", sheet 7.

⚠ WARNING:
DO NOT CUT BUS WIRES.

HLT PRODUCTS ALTERNATE METHOD

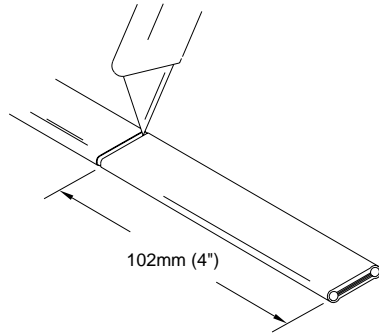

- 1 Lightly cut around heater outer jacket 102mm (4") from the end. Bend cable to break outer jacket.
- 2 Lightly cut the outer jacket up the center between the first cut mark & the cable end. Bend cable to break outer jacket.

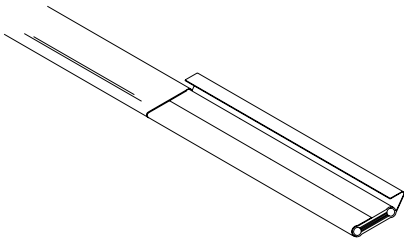

- 3 Remove the jacket from the heater cable.

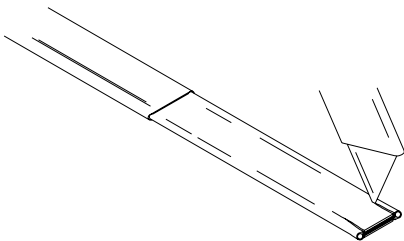

- 4 Make a cut inside each bus wire.

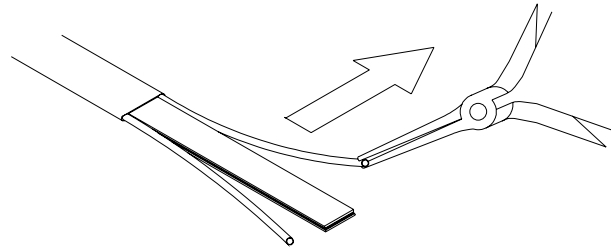

- 5 Starting at the end, in the same plane as the cable, pull each bus wire away from the core material.

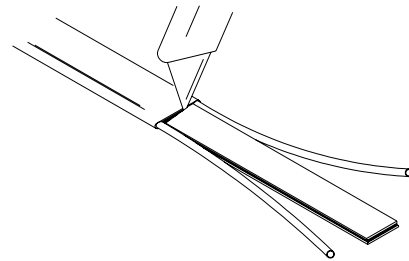

- 6 Remove exposed core material.

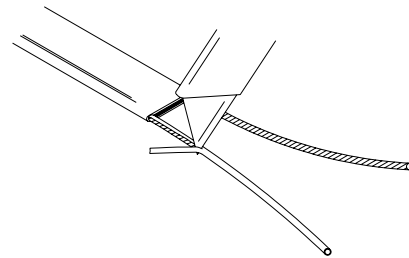

- 7 Remove the remaining core material off the outside of each bus wire.
- 8 Cut 6mm (0.25") off the end of each bus wire.
- 9 Proceed to "Power Termination", sheet 7.

POWER TERMINATION

⚠ WARNINGS:

- Bus wires must not touch or cross while inserting into power termination.
- Only power terminations / end seals specifically approved for the vendor's style and type of heater cable must be used.

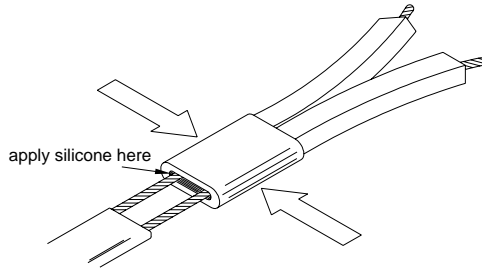

- 1 Insert bus wires into power termination.
- 2 Squeeze power termination opening and fill with silicone.

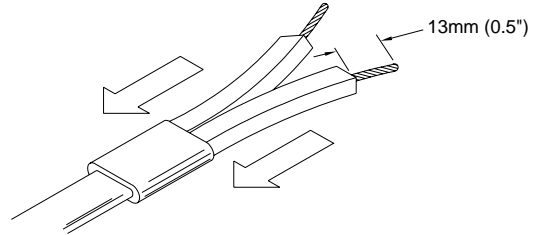

- 3 Push power termination to overlap jacket.
- 4 At this point, if you're installing the end seal, see the "End Seal" section below. Otherwise, proceed to "Power Connection", sheet 8.

END SEAL

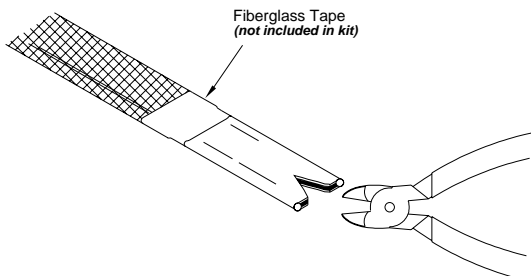

- 1 **Braided Products:**
Cut braid back 25mm (1") & tape in place with fiberglass tape; *not included in kit*.

Overjacket Products:

Remove 13mm (0.5") of overjacket exposing the braid, then remove the 13mm (0.5") of exposed braid.

- 2 Make a 10mm (0.4") cut at the end of the heater cable.

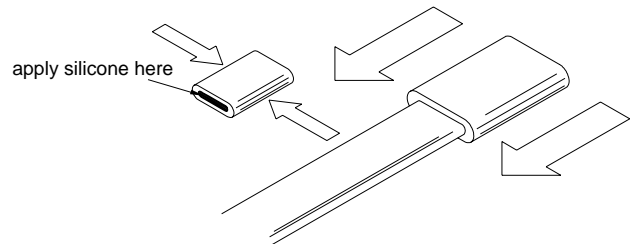

- 3 Squeeze end seal and fill with silicone.
- 4 Push end seal over the heater cable.

Overjacket Products:

The end seal should overlap the overjacket.

- 5 The silicone will set up in about 30 minutes with a complete cure after 24 hours.
- 6 Proceed to "Power Connection", sheet 8.

⚠ WARNINGS:

- Do not megger or hi-pot until silicone is completely cured.
- Braid must be kept away from bus wires or shorting will occur.

POWER CONNECTION

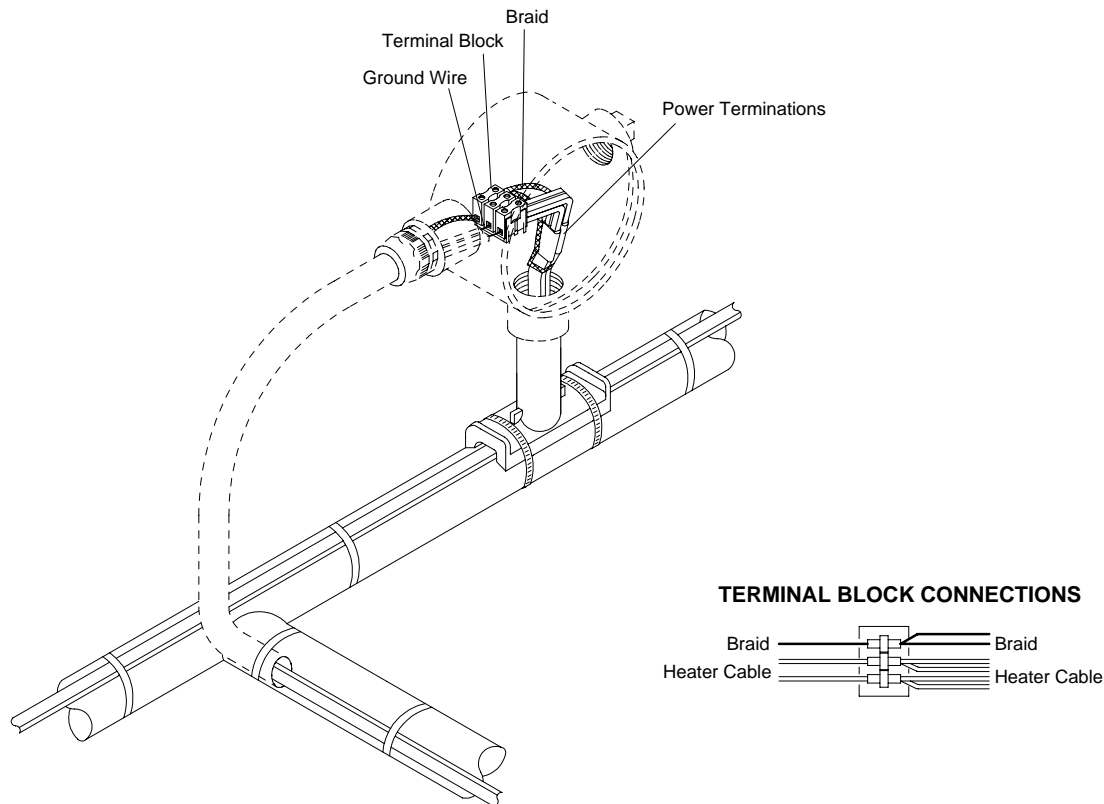

Note: This detail shows internal grounding of braid.

- ❶ Slide washer over the two heater cables and position at the sealing grommet.
- ❷ Secure junction box onto stand-off until tightly fitted. **DO NOT OVER TIGHTEN.**
- ❸ Secure the flex tubing assembly onto the junction box. *(Braid if present, should be separated from the heater cable in a pigtail as it leaves the sealing grommet entering the enclosure.)*
- ❹ Ground Connection:
For External Ground Connected Heaters:
Connect ground braid from all three heater cables together using the ground screw. *See diagram on sheet 1.*
For Internal Ground Connected Heaters:
Connect ground braid and ground wire from all heater cables to the terminal block. *See diagram above.*
- ❺ **For Overjacket J or JT Products only:**
Apply Silicone at point braid leaves the overjacket.
- ❻ Push all wires, cables and the terminal block inside junction box.
- ❼ Place box cover and box cover gasket onto the junction box.

Nelson Heat Tracing Systems products are supplied with a limited warranty. Complete Terms and Conditions may be found on Nelson's website at www.nelsonheaters.com.